



Urban CultivatorTM
FOR DEVELOPERS



What is an Urban Cultivator?

The Urban Cultivator Residential was designed with the home cook in mind. Functional and stylish, it gives you the opportunity to grow their own healthy and flavourful herbs, vegetables, microgreens, and flowers in the comfort of your own home.

Food at your fingertips

These appliances make growing your own food easy, featuring automatic humidity, lighting, and watering functions. You'll also be providing your loved ones with highly nutritious and incredibly flavorful greens that make store-bought produce pale in comparison.

For a better future

Through growing your own, you'll also be effectively eliminating your carbon footprint, removing the lengthy journey your food must travel before it reaches your table out of the equation. Growing in an Urban Cultivator Residential means that you're helping create a greener, more sustainable future.

Channel your culinary adventurer

Urban Cultivator offers over a wide variety of microgreens, vegetables, herbs, and flowers, from everyday herbs like parsley and basil, to more adventurous ones like shiso and sorrel, assisting you on your culinary journeys.



Urban Cultivator Residential

Plus, you'll be saving over \$100 per month. Can your wine cooler do that?

Urban Cultivator Residential is an appliance that's perfect for any household, whether you're living alone, or feeding a family of five.

Press

People want green in 2015.

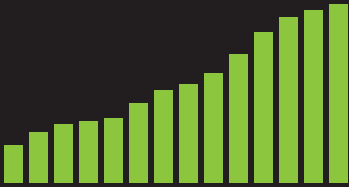

8268

The number of farmers markets in the USA.

The number of farmers markets in the United States has grown 76% since 2008. There are currently 8,268 listed in the USDA's National Farmers Market Directory. Compare that number to amount of these popular fast food chains in the United States:



KFC

4491



Pizza Hut

7846



Taco Bell

5769

Urban Cultivator Generates Press



Urban Cultivator has been on Martha Stewart's own blog several times, many news outlets, such as National Post, the Vancouver Sun, the Metro, and television stations. As well, with the Commercial units prominently featured in many high-end restaurants in Vancouver and abroad, Urban Cultivator has received a lot of media attention.

With such strong ties to the media already established—with Martha Stewart being one of our biggest fans—showcasing Urban Cultivator in your condominium can provide incredible exposure. This may also save your company a great sum of money normally spent on marketing.

The media loves Urban Cultivator



BCLiving

NATIONAL POST

THE GEORGIA straight

VANCOUVER'S NEWS & ENTERTAINMENT WEEKLY

CHATELAINE

TORONTO LIFE

TORONTO STAR

THE VANCOUVER SUN

EXCEPTIONAL STYLE

Urban Cultivator is a leader in the hydroponics industry, and our units are the future of every residential kitchen, featuring forward-thinking technology and cutting-edge design. It's an appliance that will set your building apart.



FOOD YOU CAN TRUST

What's grown in an Urban Cultivator is pesticide-free and non-GMO, giving you that peace of mind when feeding you loved ones. The fresh flavor of the wide variety of microgreens, herbs, and vegetables you can grow is just a bonus!



HEALTHY PROMISE

Giving you the freedom to harvest mere seconds before consumption, food grown in an Urban Cultivator packs a heavy punch when it comes to nutritional value. Joining the local food revolution is as easy as ever.



SUSTAINABLE DESIGN

The completely sustainable and environmentally conscious Urban Cultivator appliances makes planting microgreens, vegetables, herbs, and flowers easy. Your development will be actively reducing its residents' carbon footprints.

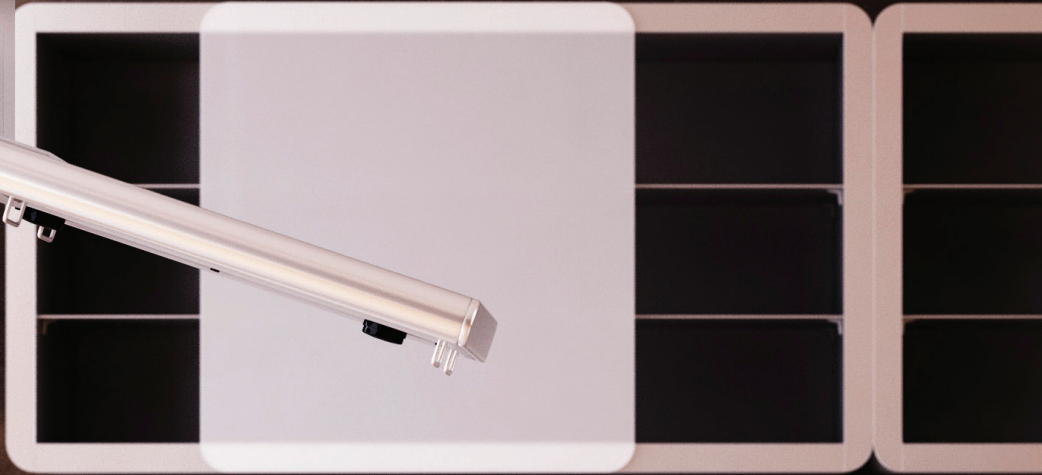

Set Your Development Apart from the Rest

What will set your development apart from the ones across the street is the fact that yours will have the best appliances the industry has to offer. This positions your company as a green developer that's a part of the quickly-growing sustainable community.



Not only that, but those using the Urban Cultivator may save up to \$150 on greens per month. When considering that store-bought greens have only a fraction of the nutritional content in that of produce grown in the Urban Cultivator, it's obvious as to which is the better choice.

Join the incredible local food movement.

Consumer demand for green appliances is growing faster than ever. According to a 2014 builder survey by the National Association of Home Builders, the top 3 priorities for new homes are:

1. Convenience

6 seconds

Harvest time from the Urban Cultivator to your plate.

2. Livability

100%

Everything grown in an Urban Cultivator is 100% fresh, organic and healthy.

3. Efficiency

\$20

Yearly energy cost of an Urban Cultivator

Product Specifications

External Dimensions

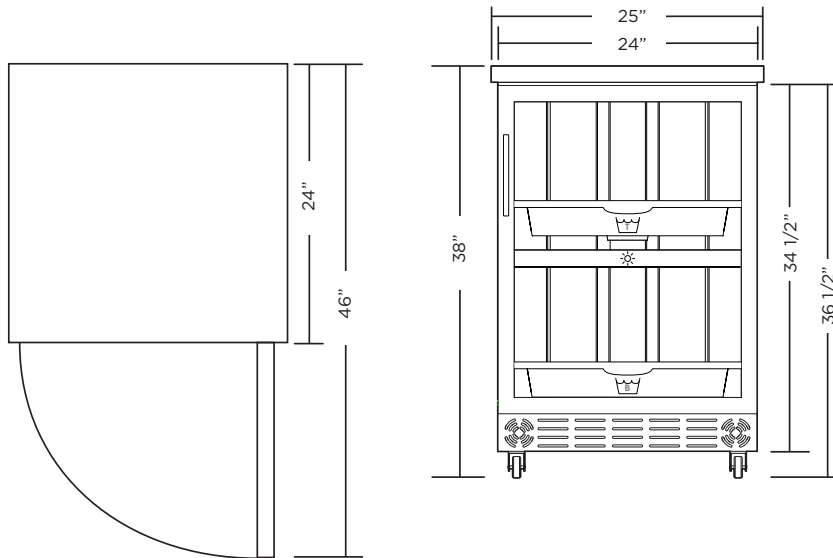

- ✔ 17 Litre Reservoir
- ✔ 3/8" Hose Connection
- ✔ Installs 5' from City Water In & Out
- ✔ Installs 2' from 110v Power

Enclosure Specifications

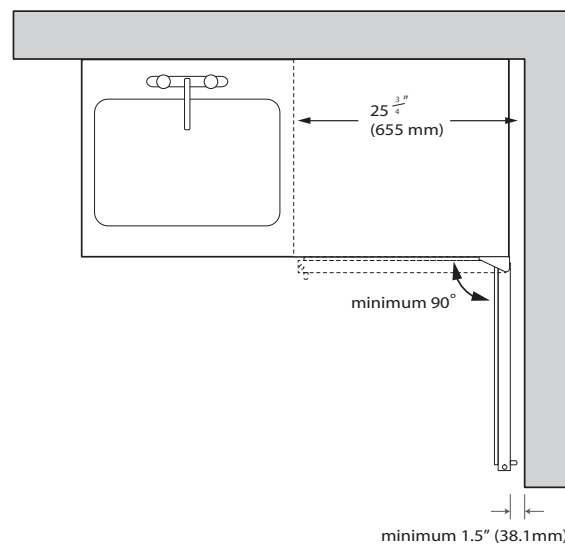
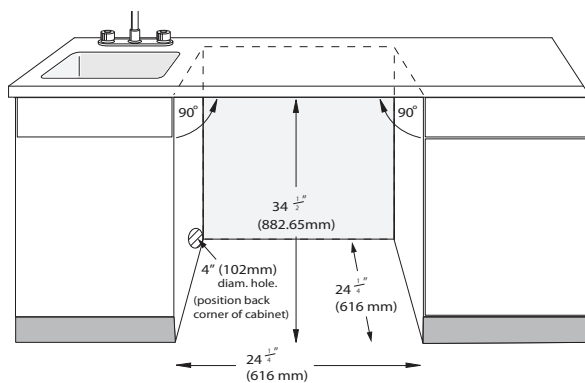

Cabinet Cut-Out Dimensions

Height 34 $\frac{1}{2}$ " Width 24 $\frac{1}{4}$ " Depth 24 $\frac{1}{4}$ "

Product Dimensions Without Counter Top Or Wheels

Height 34 $\frac{1}{4}$ " Width 24" Depth 24"

IT'S A FRESH NEW WORLD



It's a fresh new world

Unit 311 - 13060 80th Ave
Surrey, BC V3W 3B2

Toll Free: 1.877.352.0490 Local: 604.424.9929 www.urbancultivator.net